

DAVE
REDELL

6639-A DISK FILE CONTROLLER

From section IV of
Control Data 6000 Series Computer
Systems

Peripheral Equipment Reference
Manual

Pub No. 60156100 Rev B.

CONTENTS

Functional Description	1	Codes	9
System Relationship	1	Programming Considerations	14
Controller Characteristics	2	Manual Operation	17
Disk File Characteristics	4	Operating Procedures	17
Programming	9		

FIGURES

1	Typical System Configuration	2	8	Write Function Code	11
2	Disk File Disk Groupings	4	9	Read Function Code	12
3	Disk File Disks and Positioners	5	10	Disconnect Code	12
4	Track Formats	7	11	First Status Word	13
5	Connect and Status Function Code	9	12	Second Status Word	14
6	Position Select Function Code	10	13	Major and Minor Positions	16
7	Head Group Select Function Code	11			

TABLES

1	Track and Sector Efficiency Information	8	2	6639 Disk Codes	9
---	---	---	---	-----------------	---

6639-A DISK FILE CONTROLLER

The CONTROL DATA* 6638-A Disk File System consists of one 6639 Disk File Controller, one disk file, and one hydraulic cabinet assembly. An expanded system consists of two 6639 Disk File Controllers, one disk file, and one hydraulic cabinet assembly. An expanded system incorporates CONTROL DATA Standard Option 10037-A which provides an additional controller to increase system capability. A basic system maintains operations with up to two 6000 Series Data Channels, one at a time. An expanded system maintains operations with up to four 6000 Series Data Channels, two at a time.

FUNCTIONAL DESCRIPTION

SYSTEM RELATIONSHIP

The basic system shown in Figure 1 consists of one controller, physically attached between the two Data Channels and one disk file. This allows the 10 Peripheral Processors in one or more 6000 Series computers to access the two Data Channels and the one disk file. The Data Channels may simultaneously sample the conditions in the disk file through the controller, but they can operate the controller and disk file on a time-shared basis only. The disk file is divided into two sections, unit 0 and unit 1, which are mechanically and electrically independent of each other. A Data Channel can communicate with either unit 0 or unit 1, but both Data Channels cannot communicate simultaneously with their selected disk file units. For example, if Data Channel A is operating with unit 0, Data Channel B must wait until Data Channel A relinquishes operations with unit 0 before it can resume operations with unit 0 or 1.

The expanded system (Figure 1) consists of two controllers** physically attached between four Data Channels and one disk file. Since a disk file contains two units, each connected to a controller and each capable of independent operation, it allows one or more 6000 Series computers, each controlling up to ten Peripheral Processors, to perform simultaneous operations on both disk file units.

*Registered trademark of Control Data Corporation

**The second controller is a standard option. Each of the controllers is slightly modified to permit the expanded mode of operation.

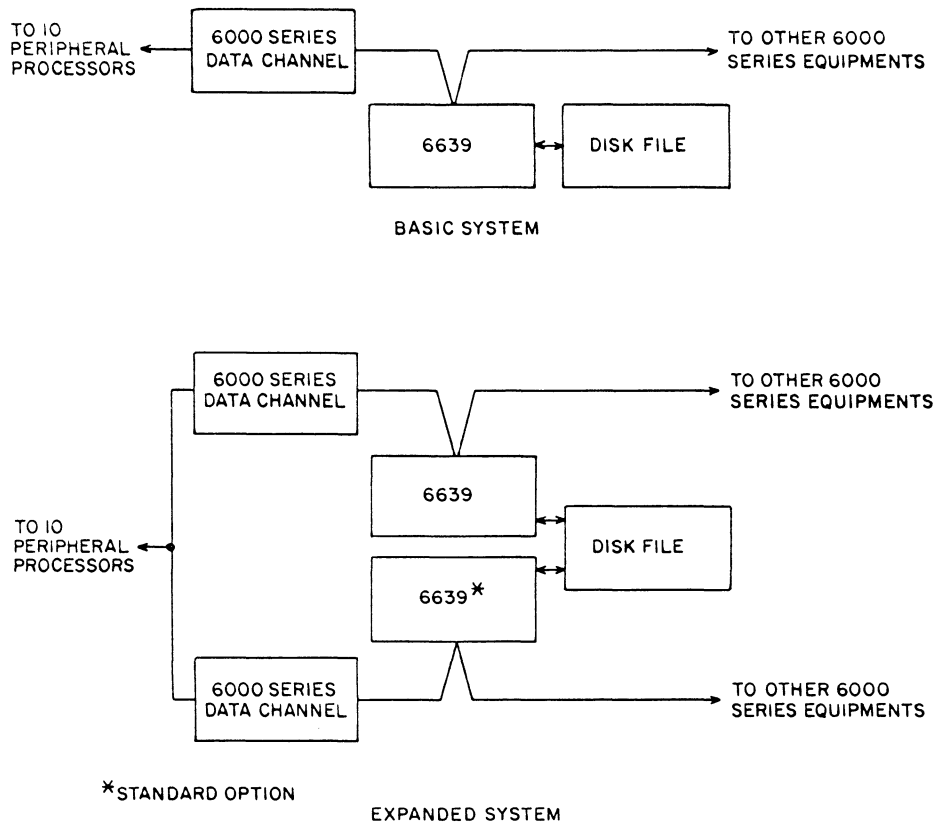

Figure 1. Typical System Configuration

CONTROLLER CHARACTERISTICS

The controller operates as an interface between the computer and the disk file. It buffers data in a 12-bit, parallel format between the computer and disk file via the Data Channel. The controller translates function codes sent by the computer program to control operations in the disk file. These codes condition the controller to connect between the proper Data Channel and disk file and to check the status of conditions within the disk file. The function codes determine from which area in the selected disk file unit the data is to be transferred. Finally, they select the operations that control the transfer of data. The controller provides timing and comparison circuits, registers, and the necessary logic to control and sequence the data handling operations.

The Data Channel issues a Function signal and output word to the controller. The Function signal causes the controller to sample the word and to define it as a function code. When the controller accepts a function word, it returns an Inactive signal to the Data Channel. Normally, functions are issued in the following sequence:

- 1) Connect and Status
- 2) Position Select
- 3) Head Group Select
- 4) Read
- 5) Write

If the function code is a Read, the Active signal (sent after the Read was replied to) signals the controller to start sending data. The controller then sends a data word together with a Full signal. When the Data Channel accepts the word, it sends an Empty signal, causing the controller to send the next word. The operations continue in this manner until the end of the read buffer. If the function code is a Write, the Active signal (sent after the Write) signals the controller that the Data Channel is ready to start sending data. The Data Channel sends a data word together with a Full signal. The controller accepts the word and returns an Empty signal, causing the Data Channel to send the next data word. The operation continues in this manner until the end of the write buffer.

The Data Channels connect to the controller on a first-come, first-served basis. The controller contains two interfaces, A and B, to accommodate the two Data Channels. If one Data Channel is connected, the other Data Channel cannot complete a connect. If both Data Channels attempt to connect to the controller at the same time, the channel wired to interface A is allowed to connect. To disconnect a connected controller, the Disconnect code (1740 or 1540) should be issued. The disconnect takes effect approximately 100 microseconds after the code is issued.

When the controller receives a Position Select function, it causes the disk file positioner to seek a new position. When the positioner reaches a null, the disk file sends an On-Point signal to the controller. The controller verifies the position address by comparing it with a Position code which has been prerecorded in serial form on one of the disk surfaces. One surface holds 32 position-codes for one 18-disk group. If the position code recorded on the track is equal to the position address specified by the function word, the read/write heads are correctly positioned. This, together with On-Point and File Ready signals, causes the controller to become Ready. A Ready condition must be present before a Read or Write operation can take place. If a Not Ready comes up during a Read or Write operation, the controller returns an Inactive signal to the Data Channel. A Status or Head Group Select function can be performed when the controller is Not Ready. A Position Select function is not accepted until an On-Point signal is received.

DISK FILE CHARACTERISTICS

The disk file provides recording surfaces for mass data storage. Each disk file contains 72 disks divided into two units (designated unit 0 and unit 1) containing 36 disks each. Each 36-disk unit is divided into two 18-disk groups. The four 18-disk groups are mounted on two shafts so that an 18-disk group from each unit is mounted on the same shaft. Two 18-disk groups mounted on one shaft are a "stack". The disk file consists of stacks 0 and 1 (as shown in Figure 2). Each shaft turns independently so that separate reference and timing signals are provided for each half (stack) of a disk file unit. The disks, the hydraulic positioner assemblies, the disk file logic, and the power supplies are contained in the disk file. The hydraulic cabinet assembly contains the hydraulic system, the air compressor, and the associated hardware.

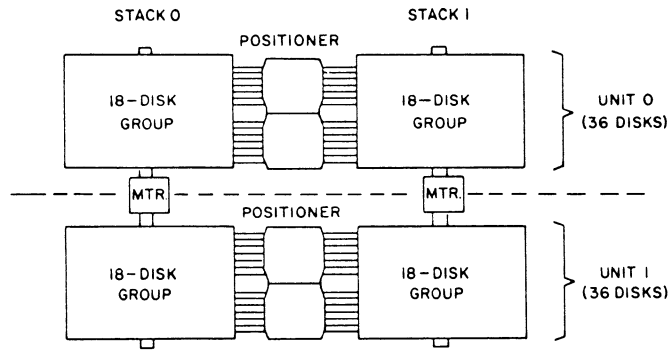

Figure 2. Disk File Disk Groupings

Surfaces

Each of the two 18-disk groups within a disk file unit is divided into two 9-disk groups. Each disk file unit, therefore, contains four 9-disk groups. Each 9-disk group contains 18 disk surfaces of which 16 are used for data storage. The remaining two surfaces in each group are either used for data synchronization or are not used. An entire disk file contains 144 disk surfaces (eight 9-disk groups times 18 disk surfaces) consisting of 128 data storage surfaces (eight 9-disk groups times 16 data storage surfaces). The remaining 16 surfaces (eight 9-disk groups times two non-data surfaces) consist of ten surfaces that are not used and six surfaces that are used to time Data Transfer operations. Four of the six surfaces are used for position verification. The remaining two surfaces contain write clock and sector marks for the two stacks.

Accessing

Each data storage surface is accessed by six read/write heads, three of which are selected at any one time. Since one head group contains 12 read/write heads, it accesses a total of 12 tracks on four disk surfaces at any one time. The two head arm assemblies, thus provide the capability of transferring 12 bits (1 byte) simultaneously to and from the disk file. Thirty-two head groups are used to access one disk file unit. These 32 head groups are mounted on a movable assembly (positioner). For the entire disk file, two positioners are used containing a total of 64 head groups. There are 768 read/write heads (12 read/write heads times 64 head groups) in the entire disk file. In addition, there are two fixed heads accessing the two disk surfaces which contain write clock and sector marks as shown in Figure 3.

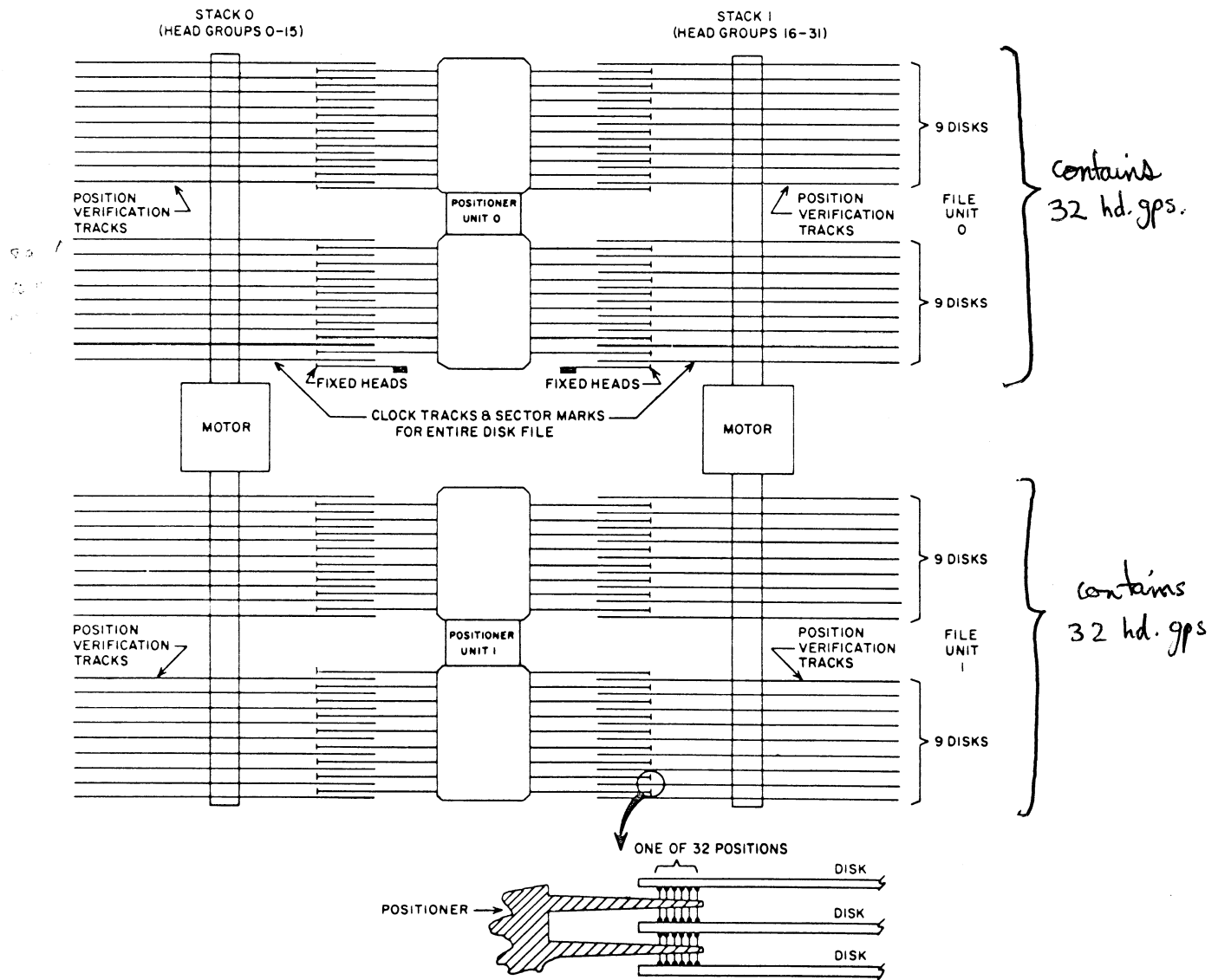

Figure 3. Disk File Disks and Positioners

Clock Track

Each data storage surface contains 192 tracks^{*} in which data can be recorded. The placement of data on each track is synchronized with pulses that have been permanently recorded on one track (clock track) of a non-data surface. The clock track contains 43,000 Write Clock pulses and 100 evenly spaced Sector Mark pulses. Each sector thus contains 430 Clock pulses. Refer to Figure 4. In addition, there are 24 extra pulses which provide for closure and index mark jitter. Separate clock tracks are provided for each of two stacks. Each clock track is accessed by a fixed head. Since the permanently recorded pulses on the clock track determine data placement, each track on a data surface is divided into 100 sectors and holds a maximum of 43,000 bits minus preamble and postamble bits.

Records

A record refers to a quantity of data which is written continuously over one or more sectors. Writing starts at a selected sector mark and stops at the end of the buffer. Since the capacity of each Peripheral Processor memory is approximately 4000 words (4096 words minus the computer program), the practical record size is restricted to a maximum of 10 sectors. Each record written on a track contains a preamble of 80 bits and a postamble of at least 28 bits. Preamble and postamble bits are provided as gaps between records (refer to Figure 4). A record always begins with a selected sector mark as a reference point. The preamble contains alternating "0" and "1" bits. Two "1" bits in succession signify the beginning of data. Since each record requires at least 108 preamble and postamble bits, the transfer of larger records allows the utilization of more track surface for the recording of data (greater track efficiency). Refer to Table 1 for information on record sizes and their relationship to track and sector efficiency.

Data Capacity

Each track has a maximum practical capacity of 42,892 data bits (one record or 43,000 bits minus the 108-bit preamble and postamble). One disk surface, therefore, can contain a maximum of 8,235,264 data bits (192 tracks times 42,892 data bits). An entire disk file can contain 1,054,113,792 data bits (128 data storage surfaces times 8,235,264 data bits) or 175,685,632 6-bit characters.

~~* A track means 3 data streams for the 3 heads in a group on that surface. So, 3 major pos, each having 2 h.w. gaps, each having 3 data positions. $3 \times 2 \times 3 \times 2 = 12$~~

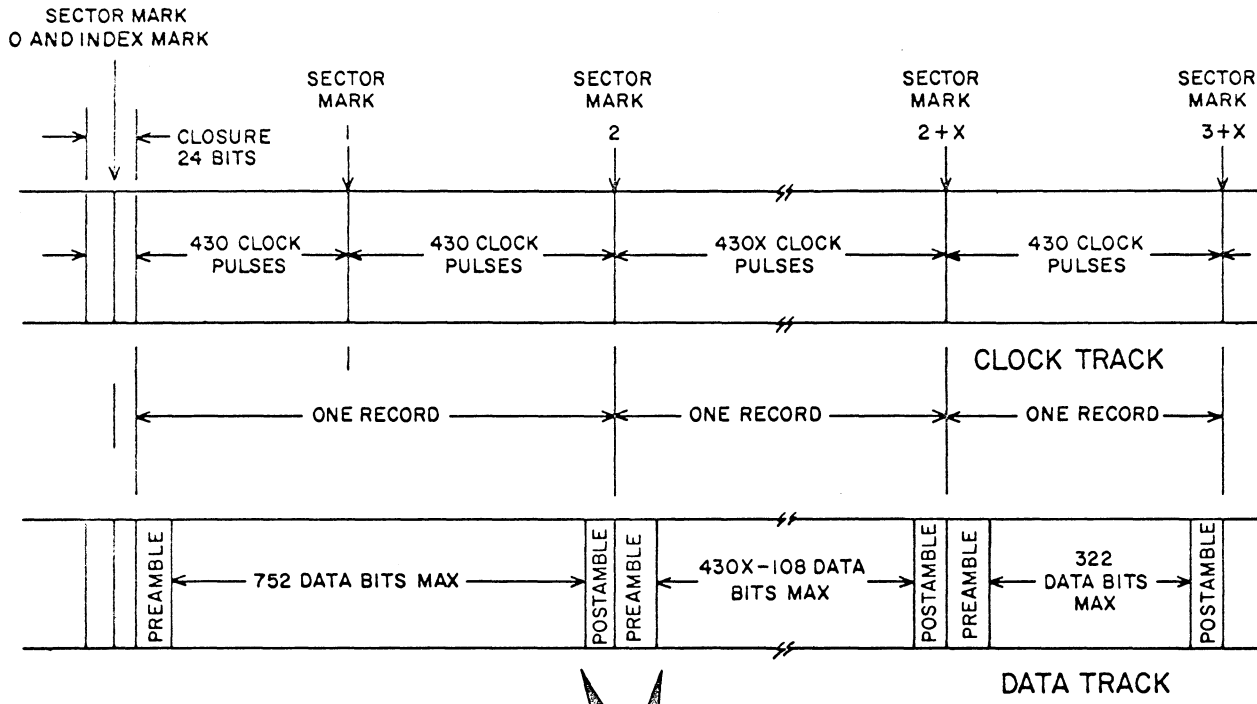

X = A QUANTITY OF SECTORS,
MAY BE 1 TO 100.

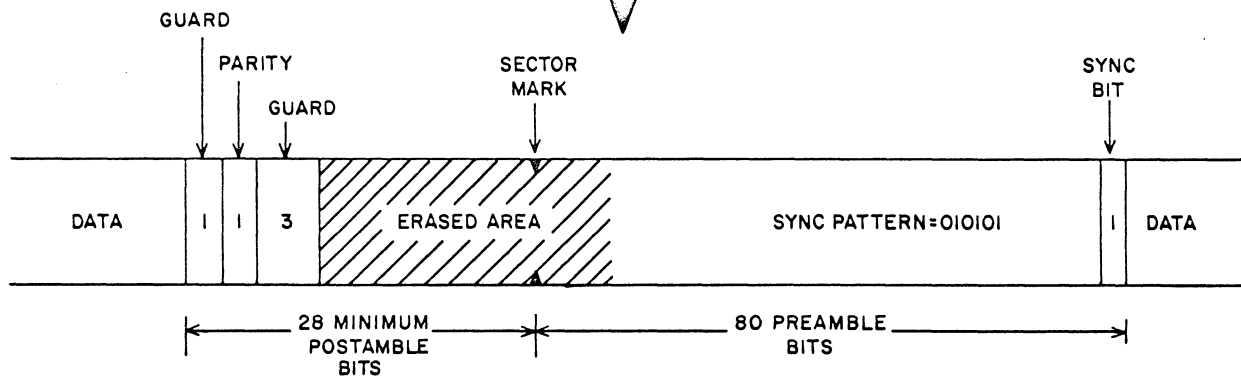

Figure 4. Track Formats

TABLE 1. TRACK AND SECTOR EFFICIENCY INFORMATION

NUMBER OF RECORDS	NUMBER OF SECTORS IN EACH RECORD	SIZE OF EACH RECORD (BITS OF DATA)	TRACK EFFICIENCY*	SECTOR EFFICIENCY**
100	1	1 to 322	0 to 75	100
50	2	323 to 752	38 to 87	100
33	3	753 to 1182	58 to 91	99
25	4	1183 to 1612	69 to 94	100
20	5	1613 to 2042	75 to 95	100
16	6	2043 to 2472	76 to 92	96
14	7	2473 to 2902	81 to 95	98
12	8	2903 to 3332	81 to 93	96
11	9	3333 to 3762	85 to 96	99
10	10	3763 to 4192	87 to 97	100

*Percentage of track used for recording data

**Percentage of available sectors in a track being utilized

Head Groups

Each disk file unit contains 32 head groups selectable by function. Each head group contains 12 read/write heads. Since the 32 head groups are mounted on one positioner, internal electronic switching is provided to allow 384 tracks to be accessed at one position (32 head groups times 12 read/write heads). Each stack in the disk file contains 16 head groups. The head groups in stack 0 are designated 0 through 15₁₀ and the head groups in stack 1 are designated 16₁₀ through 31₁₀. The head groups are designated identically in both disk file units.

Positions

The positioner in each disk file unit can move to 32 positions which are selectable by function. The positioner in each disk file unit is capable of accessing 12,288 data tracks (32 positions times 384 data tracks). Also, each positioner can move to a non-data or retract position, selectable by function. (i.e. There are 3 minor pos x 11 major pos = 33 pos → 32 data

+ 1 retract)

PROGRAMMING

CODES

TABLE 2. 6639 DISK CODES

FUNCTION CODES	
Connect and Status	15XX or 17XX
Position Select	14XX
Head Group Select	16XX
Write	12XX or 13XX
Read	10XX or 11XX
Disconnect	154X or 174X
STATUS WORDS	
First Status Word	XXXX
Second Status Word	XXXX

Function Codes

Connect and Status (15XX or 17XX)

This code interconnects the Data Channel, controller, and disk file. It also causes the controller to return one of two status words to the Data Channel. The code bit assignment is shown in Figure 5.

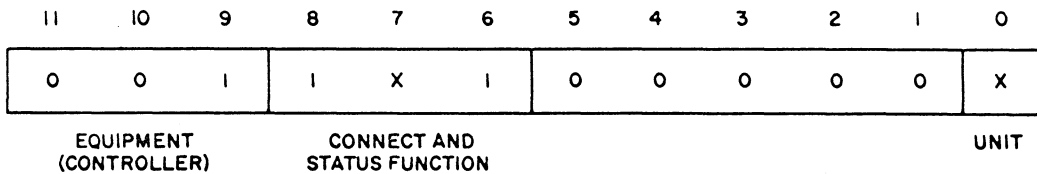

Figure 5. Connect and Status Function Code

Bits 9-11: These bits designate the equipment code number (controller) to which two Data Channels are wired. If desired, the equipment code number can be altered by a small wiring change.

Bits 6-8: This bit combination attempts to connect the controller to the Data Channel and it designates one of two formats of a status word to be returned by the controller. If bit 7 (17XX) is a "1", the controller responds with the first status word. If bit 7 (15XX) is a "0", the controller responds with the second status word. Either bit combination attempts to connect the controller to the Data Channel. Whether or not a connect is made, the controller responds with the status word designated by bit 7. If a connect is not made, any functions other than status hang up the channel.

Bits 1-5: These bits are not used.

Bit 0: (Not applicable if Standard Option 10037 is used.) This bit designates one of two disk file units to be selected. All further operations are performed on the selected unit.

Position Select (14XX)

This code causes the access mechanism to seek one of 32 positions in the disk file (refer to Figure 6).

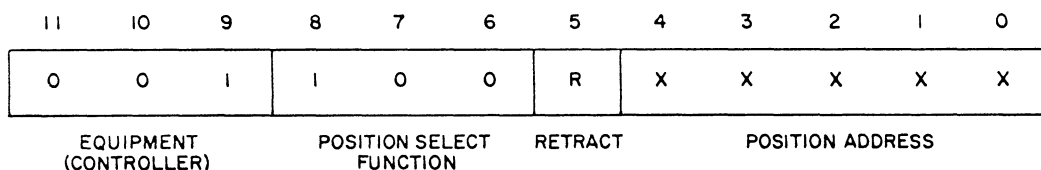

Figure 6. Position Select Function Code

Bits 9-11: These bits designate the controller to which the Data Channels are wired.

Bits 6-8: These bits designate the Position Select function.

Bit 5: When this bit is a "1", it causes the positioner to withdraw the read/write heads from the data zone to a non-data zone. This withdrawn position is provided as a standby location in which the read/write heads may reside with a low risk of data loss in the event of hardware failure.

Bits 0-4: These bits designate one of 32 positions in the disk file which are available to the access mechanism.

Head Group Select (16XX)

This code causes the selection of one of 32 head groups in the disk file (refer to Figure 7).

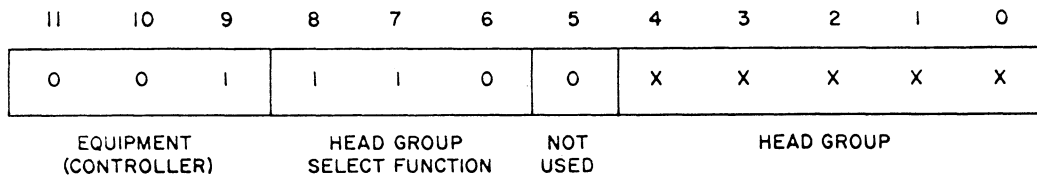

Figure 7. Head Group Select Function Code

Bits 9-11: These bits designate the controller to which the Data Channel is wired.

Bits 6-8: These bits designate the Head Group Select function.

Bit 5: This bit is not used.

Bits 0-4: These bits select one of 32 head groups in the disk file. When bit 4 is a "0", a head group in stack 0 (head groups 0 through 15) is being selected, and when bit 4 is a "1", a head group in stack 1 (head groups 16 through 31) is being selected.

Write (12XX or 13XX)

This code initiates a variable-length Write operation in the disk file (refer to Figure 8). The controller automatically generates and writes a check byte at the end of the write buffer. This byte is checked at the end of each Read operation to verify the accuracy of data transmission. Writing is end-around within a head group.

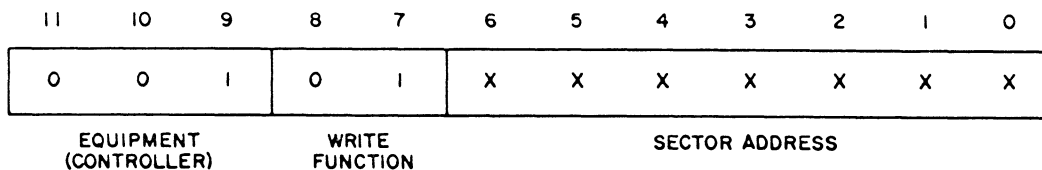

Figure 8. Write Function Code

Bits 9-11: These bits designate the controller to which the data channel is wired.

Bits 7 and 8: These bits designate the Write function.

Bits 0-6: These bits designate the address of the sector mark at which the Write operation is to begin.

Read (10XX or 11XX)

This code initiates a variable-length Read operation in the disk file (refer to Figure 9). At the end of the input buffer, the controller checks the next byte read from the disk file to verify the accuracy of data transmission. This byte was generated and written by the controller during the Write operation. Reading is end-around within a head group.

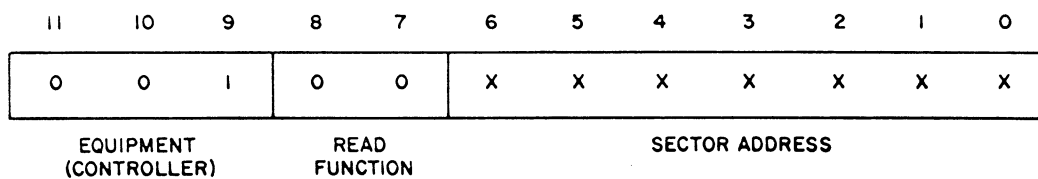

Figure 9. Read Function Code

Bits 9-11: These bits designate the controller to which the Data Channel is wired.

Bits 7 and 8: These bits designate the Read function.

Bits 0-6: These bits designate the address of the sector mark at which the Read operation is to begin.

Disconnect (154X or 174X)

This code disconnects the Data Channel from the controller approximately 100 microseconds after the instruction is executed. The controller will not respond with a status word after the Disconnect function (refer to Figure 10).

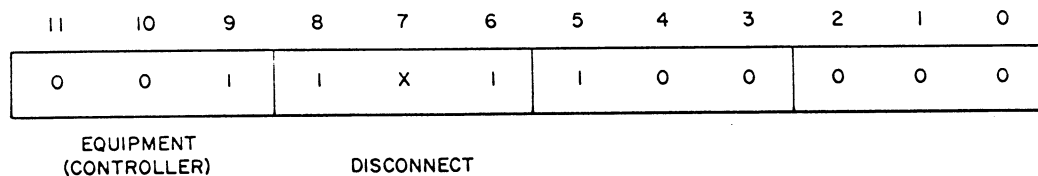

Figure 10. Disconnect Code

Bits 9-11: These bits designate the controller to which the Data Channel is wired.

Bits 5-8: These bits designate the Disconnect function.

Bits 0-4: These bits are not used.

Status Words

First Status Word (XXXX)

When bit 7 of the Connect and Status function code is a "1", the controller returns the status word shown in Figure 11.

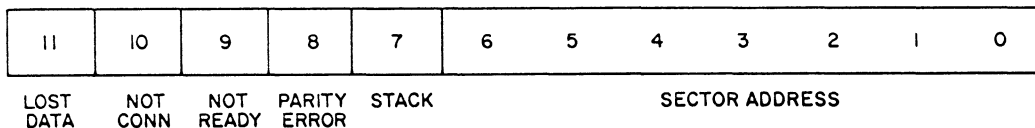

Figure 11. First Status Word

Bit 11: This bit is a "1" if a Lost Data condition occurs during a Read or Write operation. For example, the input or output buffer must follow a Read or Write function, respectively, within 90 microseconds or data is lost. The lost data bit remains present until a new Read or Write function is issued. If a lost data error occurs, the controller returns an Inactive signal to the Data Channel.

Bit 10: This bit is a "1" if the Data Channel has failed to connect to the controller because the controller has already been connected by the other Data Channel. No function other than status can be performed until a connect has been made.

Bit 9: This bit is a "1" when a Disk File Fault condition exists or when the disk file accessing mechanism is not yet verified as being "on track". No functions other than status can be performed when a Disk File Fault condition exists. All functions except a Read, Write, or Position Select can be performed when not on track. Any Read or Write function that is attempted when the disk file accessing mechanism is not on track is held up until on track is verified. A Position Select function is issued to the disk file only when an On-Point signal is present.

Bit 8: This bit is a "1" if a parity error was detected at the end of a Read operation and it remains present until a new Read or Write function is issued by program control.

Bit 7: This bit indicates to which stack the sector address (bits 0-6) refers. When this bit is a "0", stack 0 was the last stack used; when the bit is a "1", stack 1 was last used. This bit is always equal to bit 4 of the last Head Group Select function code.

Bits 0 through 6: These bits indicate the sector count plus one of the sector currently under the read/write heads. These bits are derived from the sector mark counters, and they reflect the sector address from the stack designated by bit 7.

Second Status Word (XXXX)

When bit 7 (17XX) of the Connect and Status function code is a "0", the controller returns the status word shown in Figure 12. This word indicates the last position addresses issued from the controller to each of the disk file units.

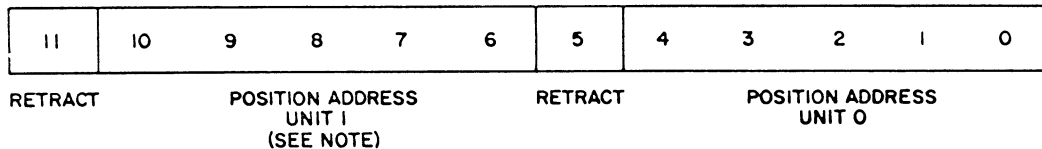

NOTE

If Standard Option 10037 is used, bits 6 through 11 are "0's".

Figure 12. Second Status Word

PROGRAMMING CONSIDERATIONS

Sequencing Operations

After a connect has been made, functions can be issued in any order. Normally, functions are issued in the following sequence: Connect and Status, Position Select, Head Group Select, and Read or Write. Once a position and a head group have been selected, it is not necessary to reselect them for subsequent operations. For optimum use of the disk file system, two processors should be used.

At the end of a Read or Write operation, a status check should be performed to check for abnormal conditions such as Lost Data, Not Connected, Parity Error, or Not Ready. Status checks performed between sectors must be part of a very rapid sequence. If the postamble is of minimum size (28 bits), there will be only about 30 microseconds to perform the following:

- 1) Check Data Channel activity to see if the Data Channel was deactivated by the controller.
- 2) Deactivate the Data Channel if at the end of the buffer and the Data Channel is still active.
- 3) Issue Connect and Status function word.
- 4) Activate the Data Channel.
- 5) Input the status word.
- 6) Check the status word.
- 7) Deactivate the Data Channel.
- 8) Issue a new function word.

Positioning Times

There are 11 major positions spaced 0.370 inch apart. Each major position includes two minor positions spaced 0.020 inch to the right or left of each major position. This results in 33 possible positions of which 32 (positions 0 through 31) are available as data positions under program control. Refer to Figure 13 for position assignments. Position and access time are as follows:

<u>Position</u>	<u>Milliseconds (maximum)</u>
Adjacent major move	45
Average of several maximum positioning times between extreme major positions	110
Single minor move (0.020 inch)	20
Double minor move (0.040 inch)	25
Verification time	250 (microseconds maximum)
Latency time	52
Average of several worst-case access times (access time includes positioning, verification, and latency times)	162.25

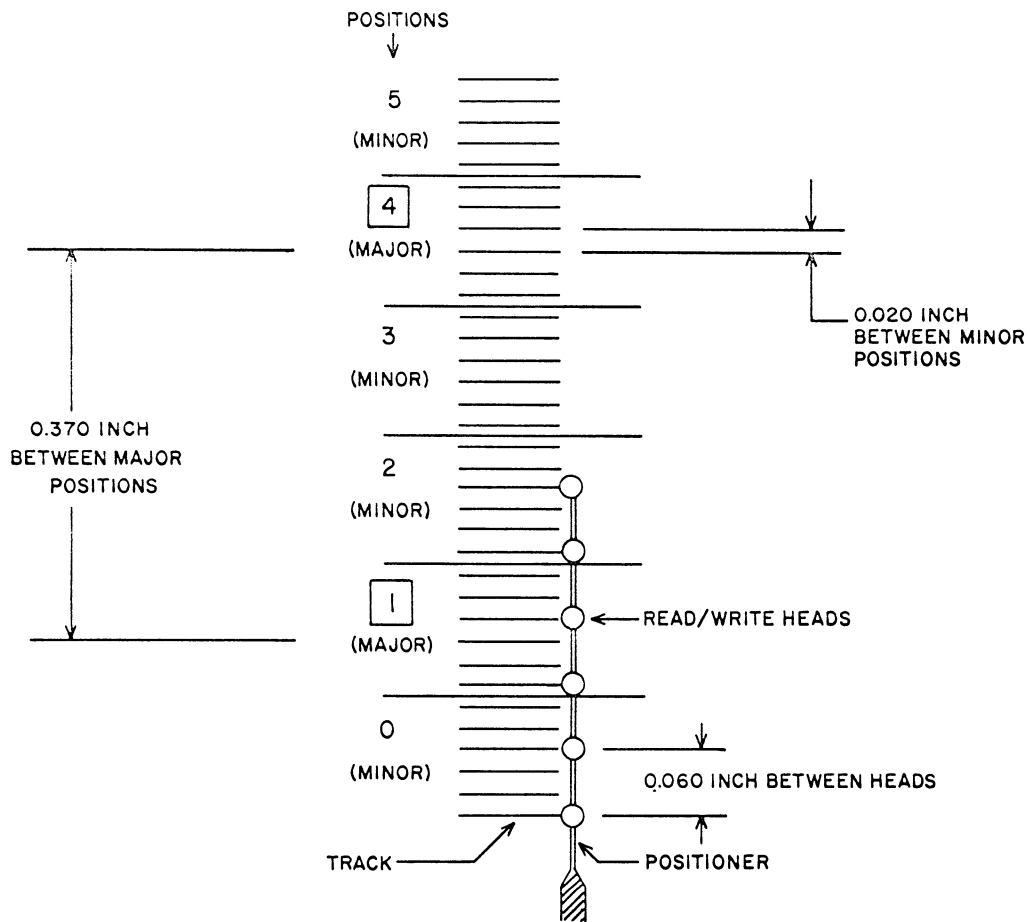

Figure 13. Major and Minor Positions

Head Switching

Since the preamble and postamble gap between sectors is at least 108 bits (129.6 microseconds) and head switching time is approximately 60 microseconds, the read/write heads can be switched between sectors. If the switching involves a new stack, there is a delay of at least 4 milliseconds before a Ready is present. This time is needed for the disk file positioning mechanism to send an On-Point signal to the controller.

Seek Overlap and Position Hold

Each disk file unit stores the last position and head group address issued to it. Thus, it is possible to have one disk file unit positioning while the other unit is reading, writing,

switching heads, or positioning. It is also possible to have both units retain their position so that a larger amount of disk storage surface is available with no positioning delay. To transfer operations from one disk file unit to another, a Connect and Status function must be issued. There are three restrictions to these capabilities:

- 1) A Not Ready is present for at least 4 milliseconds after any Position Select function is issued.
- 2) There may be a delay of up to 250 microseconds to verify the new position when the operation is transferred to another unit.
- 3) If the operation is transferred to a new stack, there will be a delay of at least 4 milliseconds.

Data Transfer Rates

Data transfer takes place at the following rates:

- 1) The parallel 12-bit (byte) transfer rate is a nominal 847 kHz.
- 2) The nominal bit-to-bit (or byte-to-byte) transfer rate is 1.18 microseconds.

MANUAL OPERATION

OPERATING PROCEDURES

To bring the system up from a Power-Off state, turn on the main 400- and 60-hertz distribution power. The distribution boxes are usually located on a wall adjacent to the disk file and controller. Perform the following procedures:

- 1) Check that circuit breaker CB1 in the controller is turned on.
- 2) Open the end panel on the disk file to expose the maintenance panel. Make sure that all the toggle switches are in the down position (automatic operation) and that all the circuit breakers are turned on.
- 3) Press the START indicator switch on the end panel.
- 4) Open the large panels on the back side of the disk file to expose two maintenance panels. The top maintenance panel is for unit 0 and the bottom panel is for unit 1. Place the MODE switches on both panels in the NORMAL position.

- 5) Allow the disk file to run for 15 to 20 minutes. At the end of this time, check to see that the HYDRAULIC OIL TEMP indicators on the end panel are not lighted. The two READY indicators on the front side of the disk file should be lighted.
- 6) Issue an instruction to select one position (from 0 through 31) from program control to each disk file unit. This moves the disk file positioners off the retract position. The controller and disk file are now ready for program operation.